

**TIDAL DATUM**

PAPKE'S LANDING, WRANGELL  
NARROWS ALASKA, STATION ID: 9451346  
LAT: 56°40.6' N, LONG: 132°56' W

MHW	16.39
MHW	15.50
MLW	1.58
MLLW	0.00

MEAN HIGH TIDE WAS DETERMINED FROM PAPKE'S LANDING, ALASKA  
U.S.C.G.S. BRASS CAP GROUDED INTO BEDROCK STAMPED 1346B 2003  
BENCHMARK ON 07/07/2015 FROM DATA SUPPLIED BY NOAA.

- LEGEND**
- ⊗ BLM/GLO MONUMENT RECOVERED THIS SURVEY
  - ⊕ PRIMARY MONUMENT SET THIS SURVEY
  - ⊙ PRIMARY MONUMENT RECOVERED THIS SURVEY
  - SECONDARY MONUMENT SET THIS SURVEY
  - SECONDARY MONUMENT RECOVERED THIS SURVEY, 2-INCH ALUMINUM CAP IN GOOD CONDITION, UNLESS OTHERWISE NOTED
  - ⊗ SECONDARY MONUMENT RECOVERED THIS SURVEY, 1.25-INCH YELLOW PLASTIC CAP, MARKED L5 6268 IN GOOD CONDITION.
  - 6"X6" YELLOW PAINTED CONCRETE HIGHWAY MONUMENT RECOVERED THIS SURVEY IN GOOD CONDITION
  - SURVEYED BOUNDARY
  - - - UNSURVEYED
  - ⊕ MITKOF HIGHWAY RIGHT-OF-WAY
  - (xxx) RECORD DATA SEE NOTE 9

**CERTIFICATE OF PAYMENT OF TAXES**

STATE OF ALASKA }  
FIRST JUDICIAL DISTRICT } ss.

I, THE UNDERSIGNED, BEING DULY APPOINTED AND QUALIFIED AND ACTING FINANCE DIRECTOR FOR THE PETERSBURG BOROUGH, DO HEREBY CERTIFY THAT, ACCORDING TO THE RECORDS OF THE PETERSBURG BOROUGH, THE FOLLOWING DESCRIBED PROPERTY IS CARRIED ON THE TAX RECORDS IN THE NAME OF: Alaska Mental Health Trust Authority

AND THAT, ACCORDING TO THE RECORDS IN MY POSSESSION, ALL TAXES ASSESSED AGAINST SAID LANDS AND IN FAVOR OF THE PETERSBURG BOROUGH ARE PAID IN FULL; THAT CURRENT TAXES FOR THE YEAR 2018 WILL BE DUE ON OR BEFORE Oct 2, 2018

DATED THIS 31<sup>ST</sup> DAY OF May, 2018  
AT PETERSBURG, ALASKA.

*John A. Tow*  
FINANCE DIRECTOR - PETERSBURG BOROUGH

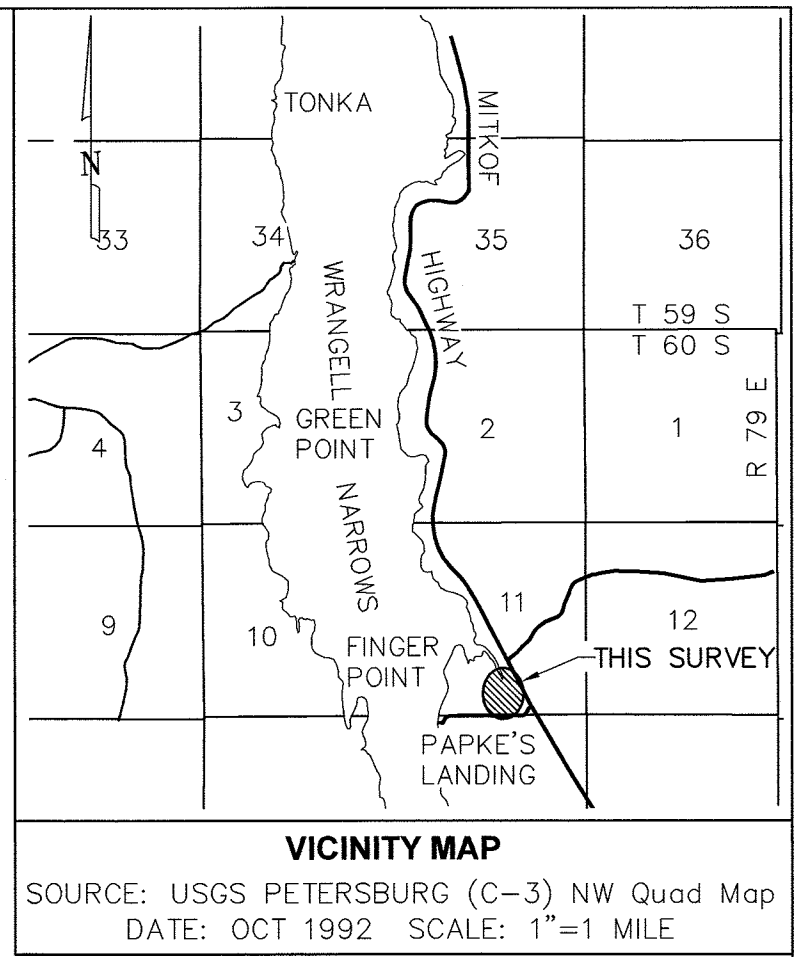

**TYPICAL SET MONUMENT DETAILS**

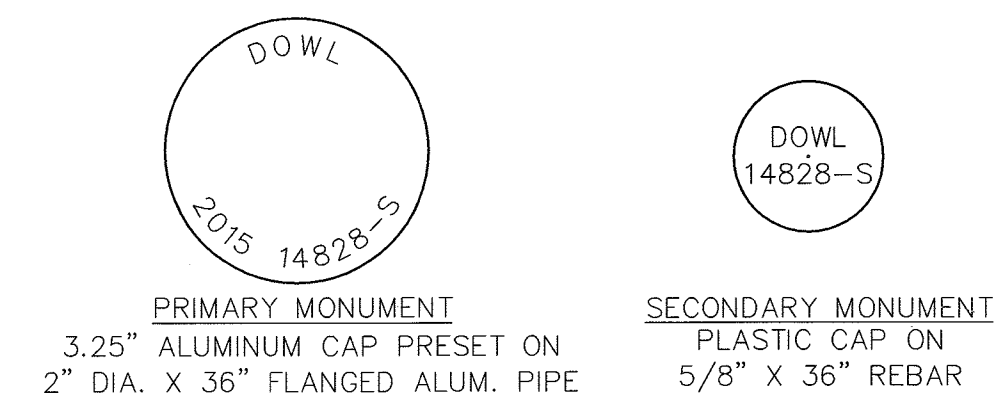

**GENERAL NOTES**

- ALL BEARINGS SHOWN ARE TRUE BEARINGS AS ORIENTED TO THE BASIS OF BEARINGS AND DISTANCES SHOWN ARE REDUCED TO HORIZONTAL FIELD DISTANCES.
- THE ERROR OF CLOSURE OF THIS SURVEY DOES NOT EXCEED 1:5000.
- ALL DISTANCES ARE MEASURED IN U.S. SURVEY FEET.
- THE NATURAL MEANDERS OF THE MEAN HIGH WATER LINE FORMS THE TRUE BOUNDS OF LOTS 1 & 2. THE APPROXIMATE LINE OF MEAN HIGH WATER, AS SHOWN, IS FOR AREA COMPUTATIONS ONLY, THE TRUE LOT 1 & 2 CORNERS BEING ON THE EXTENSION OF THE SIDELINES AND THEIR INTERSECTION WITH THE NATURAL MEANDERS.
- THIS PLAT WAS DETERMINED BY A HIGH PRECISION GPS SURVEY, USING TRIMBLE R7 AND R8 RECEIVERS, DIFFERENTIALLY CORRECTED AND PROCESSED WITH TRIMBLE BUSINESS CENTER, VER. 3.50 SOFTWARE.
- THIS PLAT IS SUBJECT TO AN EASEMENT RESERVATION TO THE STATE OF ALASKA FOR PUBLIC HIGHWAYS UNDER A.S. 19.10.010.
- THE PETERSBURG BOROUGH RESOLUTION NUMBER 2013-4, PASSED AND APPROVED ON FEBRUARY 4, 2013, AUTHORIZED THE ALASKA DEPARTMENT OF NATURAL RESOURCES TO ACT AS THE PLATTING AUTHORITY FOR THE PETERSBURG BOROUGH UNTIL REGULATIONS AND PROCEDURES ARE ADOPTED BY THE PETERSBURG BOROUGH TO EXERCISE PLATTING AUTHORITY.
- THIS PLAT IS SUBJECT TO RESERVATIONS AND EXCEPTIONS AS CONTAINED IN US PATENT NUMBER 1233083.
- RECORD INFORMATION DERIVED FROM:  
\*(R1) PETERSBURG PLAT No. 2010-2, FALLS CREEK FISH LADDER SUBDIVISION.  
\*(R2) PETERSBURG PLAT No. 90-20, HEIMDAHL SUBDIVISION II.  
\*(R3) PETERSBURG PLAT No. 2002-14, FALLS CREEK SUBDIVISION.  
\*(R4) PETERSBURG PLAT No. 84-23, HEIMDAHL SUBDIVISION.  
\*(R5) PETERSBURG PLAT No. 96-30, AK DOT&PF RIGHT OF WAY MAP SCOW BAY TO PAPKE'S LANDING, RS-0937(22).
- THE BASIS OF COORDINATES IS NAD83(2011) DETERMINED BY SURVEY GRADE GNSS OBSERVATIONS, PROCESSED THROUGH NATIONAL GEODETIC SURVEY O.P.U.S.
- LOTS WITHIN THIS SUBDIVISION MAY NOT HAVE DIRECT ACCESS TO THE MITKOF HIGHWAY OR PAPKE'S LANDING ROAD. ANY MODIFICATIONS TO EXISTING DRIVEWAYS OR CONSTRUCTION OF NEW DRIVEWAYS ONTO THE MITKOF HIGHWAY OR PAPKE'S LANDING ROAD, AN ADOT&PF PERMIT SHALL BE REQUIRED.
- PAPKE'S LANDING ROAD IS SHOWN AS PER AKDOT MAP S-937 S. STATE OF ALASKA INTEREST IN PAPKE'S LANDING ROAD, ROUTE 937 SPUR, GRANTED ON JUNE 30, 1959 BY THE OMNIBUS ACT AND RESULTING QUILCLAIM DEED RECORDED IN BOOK 18, PAGE 191 PETERSBURG RECORDING DISTRICT. ON FEBRUARY 19, 1993 THE ATTORNEY GENERAL'S OFFICE ISSUED AN OPINION CONCLUDING THAT UNDER THE ALASKA OMNIBUS ACT AND RESULTING QUILCLAIM DEED, THE STATE OF ALASKA RECEIVED, IN GENERAL, EASEMENTS FOR ITS ROADS AT STATEHOOD. PAPKE'S LANDING ROAD LIES WITHIN PARCEL CRM-2284-02 GRANTED TO ALASKA MENTAL HEALTH TRUST AUTHORITY BY STATE OF ALASKA, DEPARTMENT OF NATURAL RESOURCES ON SEPTEMBER 26, 1996 BY QUILCLAIM DEED RECORDED IN BOOK 53, PAGE 66 PETERSBURG RECORDING DISTRICT.

**CERTIFICATE OF OWNERSHIP AND DEDICATION**

I, THE UNDERSIGNED, CERTIFY THAT THE ALASKA MENTAL HEALTH TRUST AUTHORITY IS THE OWNER OF GOLDENEYE SUBDIVISION, AS SHOWN ON THIS PLAT, ON BEHALF OF THE ALASKA MENTAL HEALTH TRUST AUTHORITY. I APPROVE THIS SURVEY AND PLAT AND DEDICATE OR RESERVE FOR PUBLIC OR PRIVATE USE, AS NOTED, ALL EASEMENTS, PUBLIC UTILITY AREAS, AND RIGHTS-OF-WAY AS SHOWN AND DESCRIBED ON THIS PLAT.

*John Meneffe*  
EXECUTIVE DIRECTOR  
ALASKA MENTAL HEALTH TRUST LAND OFFICE  
2600 ORIOVA STREET, SUITE 100  
ANCHORAGE, AK 99503

**NOTARY'S ACKNOWLEDGEMENT**

SUBSCRIBED AND SWORN TO BEFORE ME THIS 23<sup>RD</sup> DAY OF April, 2018.  
BY: *John Meneffe* PERSONALLY  
APPEARING BEFORE ME.

**PLAT APPROVAL**

THIS PLAT IS APPROVED BY THE COMMISSIONER OF THE DEPARTMENT OF NATURAL RESOURCES OR THE COMMISSIONER'S DESIGNEE, IN ACCORDANCE WITH A.S. 40.15

*Suzanne M. Samuels*  
COMMISSIONER DATE: 9/20/2018

**ACCEPTANCE OF DEDICATION**

I HEREBY ACCEPTS FOR PUBLIC USES AND FOR PUBLIC PURPOSES THE REAL PROPERTY DEDICATED TO THE PUBLIC BY THIS PLAT INCLUDING EASEMENTS, RIGHTS-OF-WAY, ALLEYS AND ROADWAYS SHOWN ON THIS PLAT. THE ACCEPTANCE OF LANDS FOR PUBLIC USE OR PUBLIC PURPOSE DOES NOT OBLIGATE THE PUBLIC OR ANY GOVERNING BODY TO CONSTRUCT, OPERATE OR MAINTAIN IMPROVEMENTS.

*Mayor*  
MAYOR FOR THE PETERSBURG BOROUGH DATE: 5/31/18

**SURVEYOR'S CERTIFICATE**

I HEREBY CERTIFY THAT I AM PROPERLY REGISTERED AND LICENSED TO PRACTICE LAND SURVEYING IN THE STATE OF ALASKA, THAT THIS PLAT REPRESENTS A SURVEY MADE BY ME OR UNDER MY DIRECT SUPERVISION, THAT THE MONUMENTS SHOWN HEREON ACTUALLY EXIST AS DESCRIBED, AND THAT ALL DIMENSIONS AND OTHER DETAILS ARE CORRECT.

DATE: 8/10/18 REGISTRATION NUMBER 14828-S

*Hans E. Pierson*  
HANS E. PIERSEN  
REGISTERED LAND SURVEYOR

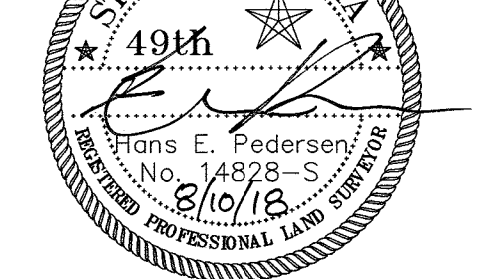

**CURVE TABLE**

CURVE NO.	RADIUS	LENGTH	DELTA	TANGENT	CHORD	CHORD BEARING
1	30.00	47.12	90°00'00"	30.00	42.43	S 45°00'00" W
2	90.00	141.37	90°00'00"	90.00	127.28	S 45°00'00" W
3	90.00	141.37	90°00'00"	90.00	127.28	S 45°00'00" E
4	30.00	47.12	90°00'00"	30.00	42.43	S 45°00'00" E
5	188.75	248.71	75°29'47"	146.14	231.10	S 52°15'06" E

**LINE TABLE**

LINE NO.	BEARING	DISTANCE
L1	S 53°36'03" E	28.77
L2	S 29°52'38" E	48.19
L3	S 30°55'53" E	58.97
L4	S 18°31'50" E	28.98
L5	S 01°21'09" W	51.34
L6	S 21°38'42" E	51.34
L7	S 39°56'31" E	64.70
L8	S 21°32'34" E	83.44
L9	S 31°07'14" E	57.64
L10	S 31°23'28" E	59.72
L11	S 12°11'27" E	31.34
L12	S 21°57'05" E	64.84
L13	S 32°38'28" E	55.72
L14	S 41°58'38" E	19.84

**SECTION LINE EASEMENT NOTE**

ALASKA MENTAL HEALTH TRUST LANDS ENCOMPASSING THE PROPOSED GOLDENEYE SUBDIVISION WERE ORIGINAL TRUST SELECTIONS (CRM-2284-02), AND WERE SURVEYED BY THE FEDERAL GOVERNMENT IN 1928. THESE LANDS WERE SELECTED AS MENTAL HEALTH LANDS UNDER THE MENTAL HEALTH ENABLING ACT, SUBJECT TO VALID AND EXISTING RIGHTS. THERE IS SUFFICIENT EVIDENCE TO SUGGEST THERE ARE VALID 33' FEDERAL SECTION LINE EASEMENTS ALONG THE SOUTHERN SECTION LINE OF SECTION 11 AND ALONG THE NORTHERN SECTION LINE OF SECTION 14.

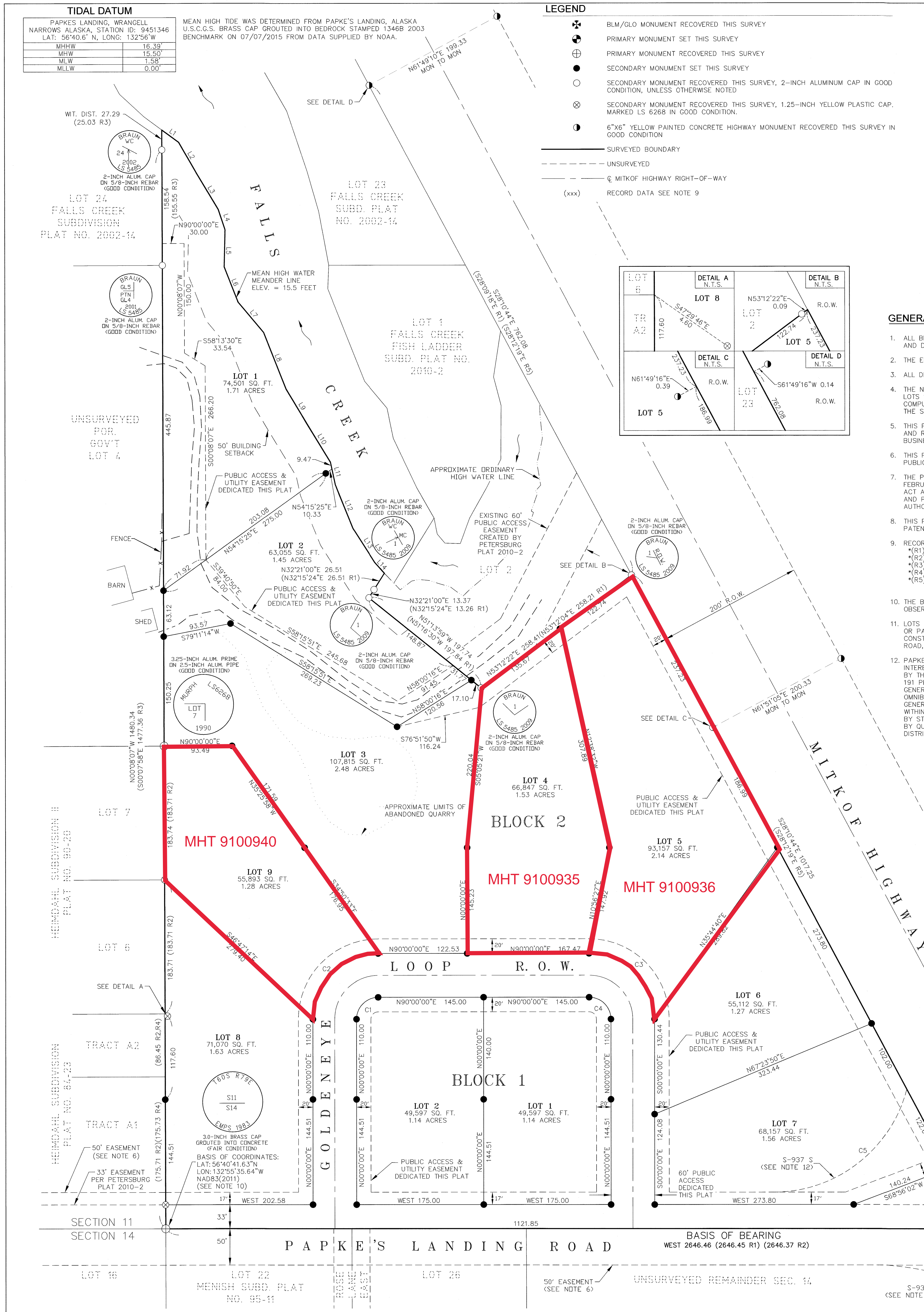
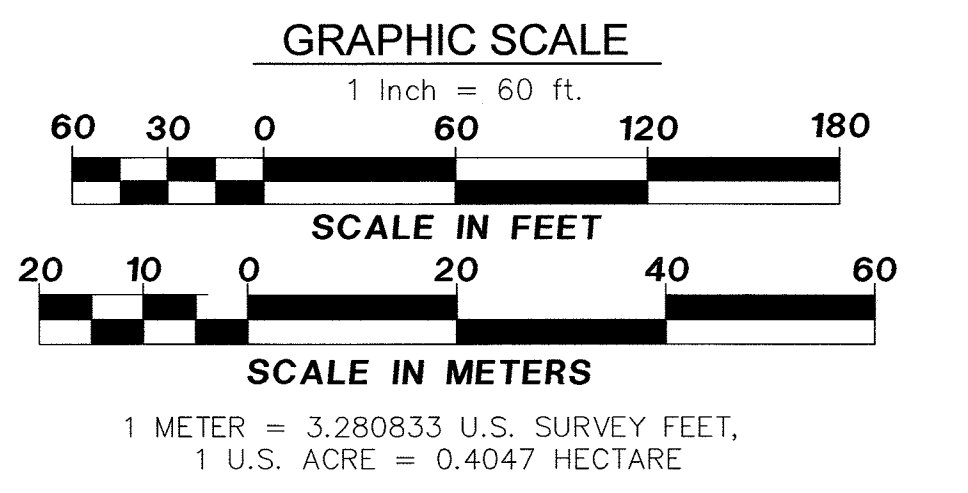

2018-14  
*Petersburg*  
DATE: 9/5/18

TRUST LAND SURVEY 2015-02

DATE OF SURVEY	SURVEYOR	DOWL
Beginning: JUNE 7, 2015		5368 COMMERCIAL BLVD.
Ending: APRIL 21, 2016		JUNEAU, ALASKA 99801
		(907)780-3533

STATE OF ALASKA  
**ALASKA MENTAL HEALTH TRUST AUTHORITY**  
ANCHORAGE ALASKA

**A PLAT OF GOLDENEYE SUBDIVISION**

CREATING LOTS 1 & 2, BLOCK 1 & LOTS 3 - 9, BLOCK 2

A SUBDIVISION OF A PORTION OF THE SE1/4, SECTION 11, TOWNSHIP 60 SOUTH, RANGE 79 EAST, COPPER RIVER MERIDIAN, ALASKA CONTAINING 19.62 ACRES PETERSBURG RECORDING DISTRICT

DRAWN BY: N.G.C.	CRM - 2284-02
DATE: APR 17, 2018	PROJECT - 2015-105
SCALE: 1" = 60'	CHECKED: D.N.R. FILE NO. PA20150043